



# EMC TEST REPORT

Applicant : EDACPOWER Electronics Co., Ltd.

---

Address : 11F-2. No.150, Jian Yi Road, Chung Ho District, New Taipei City, Taiwan. R.O.C.

---

Equipment : AC Adaptors

---

Model No. : EA1068xy, EA1068xywww  
("x" can be 1, 2, 3 or 6; "y" can be A, B, C, D, E, F, G, H, J, K, W, M, N, P, Q, R, Y, S, U, V, L or T; "w" can be 0-9, a-z, A-Z, "-" or blank)

---

Trade Name : EDAC

---

## I HEREBY CERTIFY THAT :

The sample was received on Oct. 16, 2015 and the testing was carried out on Dec. 29, 2016 at CerpPASS Technology Corp. The test result refers exclusively to the test presented test model / sample. Without written approval of CerpPASS Technology Corp., the test report shall not be reproduced except in full.

Approved by:

Ray Chou / Assistant Manager

Laboratory Accreditation:

CerpPASS Technology Corporation Test Laboratory



CerpPASS Technology(SuZhou) Co., Ltd.





## Contents

<b>1. Summary of Test Procedure and Test Results</b> .....	<b>5</b>
1.1. Applicable Standards .....	5
<b>2. Immunity Testing Performance Criteria Definition</b> .....	<b>5</b>
<b>3. Test Configuration of Equipment under Test</b> .....	<b>6</b>
3.1. Feature of Equipment under Test.....	6
3.2. Test Manner .....	7
3.3. Description of Test System.....	7
3.4. General Information of Test.....	8
3.5. Measurement Uncertainty .....	8
<b>4. Test of Conducted Emission</b> .....	<b>9</b>
4.1. Test Limit .....	9
4.2. Test Procedures .....	12
4.3. Typical Test Setup .....	12
4.4. Measurement Equipment.....	12
4.5. Test Result and Data .....	13
4.6. Test Photographs of Power Port .....	15
<b>5. Test of Radiated Emission</b> .....	<b>16</b>
5.1. Test Limit .....	16
5.2. Test Procedures .....	19
5.3. Typical Test Setup .....	19
5.4. Measurement Equipment.....	20
5.5. Test Result and Data (30MHz ~ 1GHz).....	21
5.6. Test Photographs (30MHz~1GHz) .....	23
<b>6. Harmonics Test</b> .....	<b>24</b>
6.1. Limits of Harmonics Current Measurement .....	24
6.2. Test Result and Data .....	24
<b>7. Voltage Fluctuations Test</b> .....	<b>25</b>
7.1. Test Procedure .....	25
7.2. Measurement Equipment.....	25
7.3. Test Result and Data .....	26
7.4. Test Photographs .....	27
<b>8. Electrostatic Discharge Immunity Test</b> .....	<b>28</b>
8.1. Test Procedure .....	28
8.2. Test Setup for Tests Performed in Laboratory.....	29
8.3. Test Severity Levels .....	30
8.4. Measurement Equipment.....	30
8.5. Test Result and Data .....	31
8.6. Test Photographs .....	32
<b>9. Radio Frequency Electromagnetic Field Immunity Test</b> .....	<b>33</b>
9.1. Test Procedure .....	33
9.2. Test Severity Levels .....	33
9.3. Measurement Equipment.....	33



- 9.4. Test Result and Data ..... 34
- 9.5. Test Photographs ..... 35
- 10. Electrical Fast Transient/ Burst Immunity Test ..... 36**
  - 10.1. Test Procedure ..... 36
  - 10.2. Test Severity Levels ..... 36
  - 10.3. Measurement Equipment ..... 36
  - 10.4. Test Result and Data ..... 37
  - 10.5. Test Photographs ..... 38
- 11. Surge Immunity Test ..... 39**
  - 11.1. Test Procedure ..... 39
  - 11.2. Test Severity Level ..... 39
  - 11.3. Measurement Equipment ..... 40
  - 11.4. Test Result and Data ..... 40
  - 11.5. Test Photographs ..... 41
- 12. Conduction Disturbances induced by Radio-Frequency Fields ..... 42**
  - 12.1. Test Procedure ..... 42
  - 12.2. Test Severity Levels ..... 42
  - 12.3. Measurement Equipment ..... 42
  - 12.4. Test Result and Data ..... 43
  - 12.5. Test Photographs ..... 44
- 13. Power Frequency Magnetic Field Immunity Test ..... 45**
  - 13.1. Test Setup ..... 45
  - 13.2. Test Severity Levels ..... 45
  - 13.3. Measurement Equipment ..... 45
  - 13.4. Test Result and Data ..... 46
  - 13.5. Test Photographs ..... 47
- 14. Voltage Dips and Voltage Interruptions Immunity Test Setup ..... 48**
  - 14.1. Test Conditions ..... 48
  - 14.2. Measurement Equipment ..... 48
  - 14.3. Test Result and Data ..... 49
  - 14.4. Test Photographs ..... 50





## 1. Summary of Test Procedure and Test Results

### 1.1. Applicable Standards

The measurements shown in this test report were made in accordance with the procedures given in **EUROPEAN COUNCIL DIRECTIVE 2014/30/EU**.

The energy emitted by this equipment was **passed** both Radiated and Conducted Emissions Class **B** limits.

Test Item	Normative References	Test Result
Conducted Emission	EN 55032:2012+AC:2013, AS/NZS CISPR32:2013	PASS
Radiated Emission	EN 55032:2012+AC:2013, AS/NZS CISPR32:2013	PASS
Harmonics	EN 61000-3-2:2014	N/A
Voltage Fluctuations	EN 61000-3-3:2013	PASS
EN 55024:2010		
Electrostatic Discharge Immunity Test (ESD)	IEC 61000-4-2:2008	PASS
Radio Frequency electromagnetic field immunity test (RS)	IEC 61000-4-3:2006+A1:2007+A2:2010	PASS
Electrical Fast Transient/ Burst Immunity Test (EFT)	IEC 61000-4-4:2012	PASS
Surge Immunity Test	IEC 61000-4-5:2014	PASS
Conduction Disturbances induced by Radio-Frequency Fields	IEC 61000-4-6:2013	PASS
Power Frequency Magnetic Field Immunity Test	IEC 61000-4-8:2009	PASS
Voltage Dips and Voltage Interruptions Immunity Test	IEC 61000-4-11:2004	PASS

## 2. Immunity Testing Performance Criteria Definition

- A. Normal performance within limits specified by the manufacture, requestor or purchaser.
- B. Temporary loss of function or degradation of performance which ceases after the disturbance ceases, and from which the equipment under test recovers its normal performance, without operator intervention.
- C. Temporary loss of function or degradation of performance, the correction of which requires operation intervention.
- D. Loss of function or degradation of performance which is not recoverable, owing to damage to hardware or software, or loss of data.



### 3. Test Configuration of Equipment under Test

#### 3.1. Feature of Equipment under Test

INPUT: 100-240Vac, 50-60Hz, 2.0A

Model (A)	Output voltage (Vdc) (B)	Output current (A Max.) (B)	Output power (W Max.) (B)	Transformer (T1) (P/N)
EA1068xA, EA1068xAwwww	5-9	5.0	25	183-461
EA1068xB, EA1068xBwwww	12-16	3.33	40	183-462
EA1068xC, EA1068xCwwww	18-24	2.10	40	183-459
EA1068xD, EA1068xDwwww	32-42	1.25	40	183-460
EA1068xE, EA1068xEwwww	44-56	0.90	40	183-466
EA1068xF, EA1068xFwwww	5-9	6.0	30	183-461
EA1068xG, EA1068xGwwww	12-16	4.16	50	183-462
EA1068xH, EA1068xHwwww	18-24	2.63	50	183-459
EA1068xJ, EA1068xJwwww	32-42	1.56	50	183-460
EA1068xK, EA1068xKwwww	44-56	1.13	50	183-466
EA1068xW, EA1068xWwwww	5-9	8.0	40	183-461
EA1068xM, EA1068xMwwww	5-9	7.0	35	183-461
EA1068xN, EA1068xNwwww	12-16	5.00	60	183-462
EA1068xP, EA1068xPwwww	18-24	3.15	60	183-459
EA1068xQ, EA1068xQwwww	32-42	1.87	60	183-460
EA1068xR, EA1068xRwwww	44-56	1.36	60	183-466
EA1068xY, EA1068xYwwww	12-16	5.42	65	183-462
EA1068xS, EA1068xSwwww	5-9	9.0	45	183-461
EA1068xU, EA1068xUwwww	12-16	6.00	72	183-462
EA1068xV, EA1068xVwwww	18-24	3.78	72	183-459
EA1068xL, EA1068xLwwww	32-42	2.25	72	183-460
EA1068xT, EA1068xTwwww	44-56	1.63	72	183-466



### 3.2. Test Manner

- a. During testing, the interface cables and equipment positions were varied according to Europe Standard EN 55032 Class B.
- b. The complete test system included Multi Meter, Cement Resistance and EUT for EMC test.
- c. The test modes of EMI test as follow:
  - Test Mode 1. Full Load (12V, 6A)
  - Test Mode 2. Full Load (24V, 3A)
  - Test Mode 3. Full Load (16V, 4.5A)
  - Test Mode 4. Full Load (9V, 5A)
  - Test Mode 5. Full Load (5V, 9A)
  - Test Mode 6. Full Load (19V, 3.78A)
 The "Test Mode 3" generated the worst test result, it was reported as final data.
- d. The test mode of EMS test as follow:
  - Test Mode 1. Full Load (16V, 4.5A)
- e. The maximum operating frequency is below 108MHz, the test frequency range is from 30MHz to 1GHz.

### 3.3. Description of Test System

#### EMI

Device	Manufacturer	Model No.	Description
Multi Meter	DHA	DMM-93B	N/A
Cement Resistance	Shine Time	400W, 10Ω 400W, 5Ω	N/A

#### EMS

Device	Manufacturer	Model No.	Description
Multi Meter	YEF	YF-370A	N/A
Cement Resistance	Shine Time	400W, 10Ω	N/A



### 3.4. General Information of Test

<input checked="" type="checkbox"/> Test Site	<b>Cerpass Technology Corporation Test Laboratory</b> Address: No.10, Ln. 2, Lianfu St., Luzhu Dist., Taoyuan City 33848, Taiwan (R.O.C.) Tel:+886-3-3226-888 Fax:+886-3-3226-881 Address: No.68-1, Shihbachongsi, Shihding Township, New Taipei City 223, Taiwan, R.O.C. Tel: +886-2-2663-8582		
	FCC	TW1079, TW1061,390316, 228391, 641184	
	IC	4934E-1, 4934E-2	
	VCCI	T-2205 for Telecommunication Test C-4663 for Conducted emission test R-4399, R-4218 for Radiated emission test G-812, G-813 for radiated disturbance above 1GHz	
<input type="checkbox"/> Test Site	<b>Cerpass Technology (Suzhou) Co.,Ltd</b> Address: No.66,Tangzhuang Road, Suzhou Industrial Park, Jiangsu 215006, China Tel: +86-512-6917-5888 Fax: +86-512-6917-5666		
	FCC	916572, 331395	
	IC	7290A-1, 7290A-2	
	VCCI	T-343 for Telecommunication Test C-2919 for Conducted emission test R-2670 for Radiated emission test G-227 for radiated disturbance above 1GHz	
Frequency Range Investigated:	Conducted: from 150kHz to 30 MHz Radiation: from 30 MHz to 1000MHz		
Test Distance :	The test distance of radiated emission below 1GHz from antenna to EUT is 10 M. The test distance of radiated emission above 1GHz from antenna to EUT is 3 M.		

### 3.5. Measurement Uncertainty

Measurement Item	Measurement Frequency	Polarization	Uncertainty
Conducted Emission	9 kHz ~ 30 MHz	LINE / NEUTRAL	±3.25 dB
Conducted Emission (Telecommunication Port)	9 kHz ~ 30 MHz	N/A	±4.1 dB
Radiated Emission	30 MHz ~ 1,000 MHz	Vertical / Horizontal	±3.93 dB
	1,000 MHz ~ 6,000 MHz	Vertical / Horizontal	±4.01 dB
	6,000 MHz ~ 18,000 MHz	Vertical / Horizontal	±4.72 dB

The measurement uncertainty will be considered, when test result margin to the limit.





## 4. Test of Conducted Emission

### 4.1. Test Limit

Conducted Emissions were measured from 150 kHz to 30 MHz with a bandwidth of 9 kHz and return leads of the EUT according to the methods defined in European Standard EN 55032.

**Table A.8 – Requirements for conducted emissions from the AC mains power ports of Class A equipment**

Applicable to 1. AC mains power ports (3.1.1)				
Table clause	Frequency range MHz	Coupling device (see Table A.7)	Detector type / bandwidth	Class A limits dB( $\mu$ V)
A8.1	0.15 – 0.5	AMN	Quasi Peak / 9 kHz	79
	0.5 - 30			73
A8.2	0.15 – 0.5	AMN	Average / 9 kHz	66
	0.5 - 30			60
NOTE Apply A8.1 and A8.2 across the entire frequency range.				

**Table A.9 – Requirements for conducted emissions from the AC mains power ports of Class B equipment**

Applicable to 1. AC mains power ports (3.1.1)				
Table clause	Frequency range MHz	Coupling device (see Table A.7)	Detector type / bandwidth	Class B limits dB( $\mu$ V)
A9.1	0.15 – 0.5	AMN	Quasi Peak / 9 kHz	66 – 56
	0.5 - 5			56
	5 - 30			60
A9.2	0.15 – 0.5	AMN	Average / 9 kHz	56 – 46
	0.5 - 30			46
	5 - 30			50
NOTE Apply A9.1 and A9.2 across the entire frequency range.				



**Table A.10 – Requirements for asymmetric mode conducted emissions from Class A equipment**

Applicable to					
1. wired network ports (3.1.30)					
2. optical fibre ports (3.1.24) with metallic shield or tension members					
3. antenna ports (3.1.3)					
Table clause	Frequency range MHz	Coupling device (see Table A.7)	Detector type / bandwidth	Class A voltage limits dB( $\mu$ V)	Class A current limits dB( $\mu$ A)
A10.1	0.15 – 0.5	AAN	Quasi Peak / 9 kHz	97 – 87	n/a
	0.5 - 30			87	
	0.15 – 0.5	AAN	Average / 9 kHz	84 – 74	
	0.5 - 30			74	
A10.2	0.15 – 0.5	CVP and current probe	Quasi Peak / 9 kHz	97 - 87	53-43
	0.5 - 30			87	43
	0.15 – 0.5	CVP and current probe	Average / 9 kHz	87 – 74	40 – 30
	0.5 - 30			74	30
A10.3	0.15 – 0.5	Current Probe	Quasi Peak / 9 kHz	n/a	53 – 43
	0.5 - 30				43
	0.15 – 0.5	Current Probe	Average / 9 kHz		40 - 30
	0.5 - 30				30

NOTE 1 The choice of coupling device and measurement procedure is defined in Annex C.  
 NOTE 2 AC mains power ports shall meet the limits given in Table A.8.  
 NOTE 3 The test shall cover the entire frequency range.  
 NOTE 4 The application of the voltage and/or current limits is dependent on the measurement procedure used. Refer to Table C.1 for applicability.  
 NOTE 5 Testing is required at only one EUT supply voltage and frequency.  
 NOTE 6 Applicable to ports listed above and intended to connect to cables longer than 3 m.



**Table A.11 – Requirements for asymmetric mode conducted emissions  
from Class B equipment**

Applicable to					
1. wired network ports (3.1.30)					
2. optical fibre ports (3.1.24) with metallic shield or tension members					
3. broadcast receiver tuner ports (3.1.8)					
4. antenna ports (3.1.3)					
Table clause	Frequency range MHz	Coupling device (see Table A.7)	Detector type / bandwidth	Class B voltage limits dB( $\mu$ V)	Class B current limits dB( $\mu$ A)
A11.1	0.15 – 0.5	AAN	Quasi Peak / 9 kHz	84 – 74	n/a
	0.5 - 30			74	
	0.15 – 0.5	AAN	Average / 9 kHz	74 – 64	
	0.5 - 30			64	
A11.2	0.15 – 0.5	CVP and current probe	Quasi Peak / 9 kHz	84 – 74	40 – 30
	0.5 - 30			74	30
	0.15 – 0.5	CVP and current probe	Average / 9 kHz	74 – 64	30 – 20
	0.5 - 30			64	20
A11.3	0.15 – 0.5	Current Probe	Quasi Peak / 9 kHz	n/a	40 – 30
	0.5 - 30				30
	0.15 – 0.5	Current Probe	Average / 9 kHz		30 - 20
	0.5 - 30				20
NOTE 1 The choice of coupling device and measurement procedure is defined in Annex C.					
NOTE 2 Screened ports including TV broadcast receiver tuner ports are tested with a common-mode impedance of 150 $\Omega$ . This is typically accomplished with the screen terminated by 150 $\Omega$ to earth.					
NOTE 3 AC mains power ports shall meet the limits given in Table A.9.					
NOTE 4 The test shall cover the entire frequency range.					
NOTE 5 The application of the voltage and/or current limits is dependent on the measurement procedure used. Refer to Table C.1 for applicability.					
NOTE 6 Testing is required at only EUT supply voltage and frequency.					
NOTE 7 Applicable to ports listed above and intended to connect to cables longer than 3 m.					

### 4.2. Test Procedures

- The EUT was placed on a desk 0.8 meters height from the metal ground plane and 0.4 meter from the conducting wall of the shielding room and it was kept at least 0.8 meters from any other grounded conducting surface.
- Connect EUT to the power mains through a line impedance stabilization network (LISN).
- All the support units are connecting to the other LISN.
- The LISN provides 50 ohm coupling impedance for the measuring instrument.
- The CISPR states that a 50 ohm, 50 micro-Henry LISN should be used.
- Both sides of AC line were checked for maximum conducted interference.
- The frequency range from 150 kHz to 30 MHz was searched
- Set the test-receiver system to Peak Detect Function and Specified Bandwidth with Maximum Hold Mode.

### 4.3. Typical Test Setup

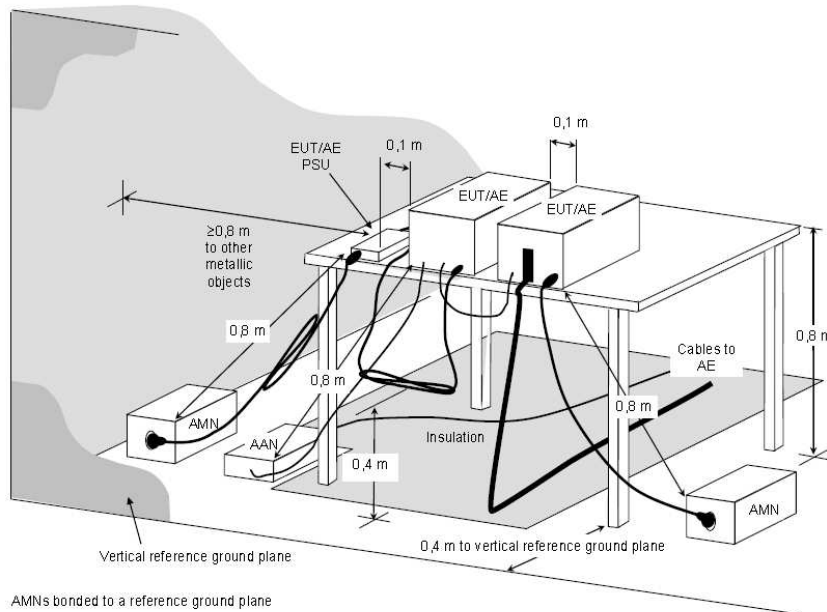

NOTE: The 0,8 m distance specified between EUT/AE/PSU and AMN/AAN, is applicable only to the EUT being measured. If the device is AE then it shall be  $\geq 0,8$  m.

**Figure D.2 – Example measurement arrangement for table-top EUT (Conducted emission measurement – alternative 1)**

### 4.4. Measurement Equipment

Instrument	Manufacturer	Model No.	Serial No.	Calibration Date	Valid Date
EMI Receiver	R&S	ESCI3	101423	2016/04/08	2017/04/07
LISN	Schwarzbeck	NSLK 8127	8127-740	2016/08/30	2017/08/29
Pulse Limiter	R&S	ESH3-Z2	101933	2016/08/29	2017/08/28
Software	Farad	Ez-EMC	ver.ct3a1	N/A	N/A



4.5. Test Result and Data

Power	: AC 230V	Pol/Phase	: LINE
Test Mode	: Mode 3	Temperature	: 22°C
Test Date	: Dec. 27, 2016	Humidity	: 60%

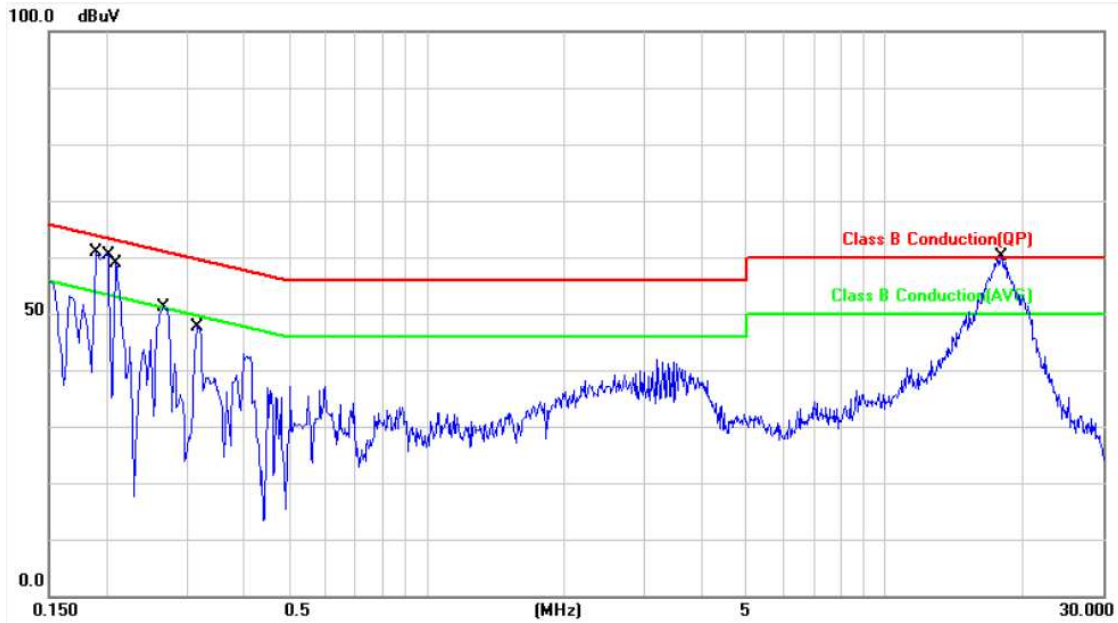

No.	Frequency (MHz)	Factor (dB)	Reading (dBuV)	Level (dBuV)	Limit (dBuV)	Margin (dB)	Detector	P/F
1	0.1900	9.97	50.66	60.63	64.03	-3.40	QP	P
2	0.1900	9.97	30.16	40.13	54.03	-13.90	AVG	P
3	0.2020	9.97	48.20	58.17	63.52	-5.35	QP	P
4	0.2020	9.97	31.24	41.21	53.52	-12.31	AVG	P
5	0.2100	9.97	45.55	55.52	63.20	-7.68	QP	P
6	0.2100	9.97	23.76	33.73	53.20	-19.47	AVG	P
7	0.2660	9.97	38.31	48.28	61.24	-12.96	QP	P
8	0.2660	9.97	21.42	31.39	51.24	-19.85	AVG	P
9	0.3180	9.96	33.45	43.41	59.76	-16.35	QP	P
10	0.3180	9.96	16.70	26.66	49.76	-23.10	AVG	P
11	18.0140	10.46	43.15	53.61	60.00	-6.39	QP	P
12	18.0140	10.46	32.28	42.74	50.00	-7.26	AVG	P

Note: Level = Reading + Factor  
Margin = Level – Limit  
Factor = (LISN, ISN, PLC or current probe) Factor + Cable Loss + Attenuator



Power	: AC 230V	Pol/Phase	: NEUTRAL
Test Mode	: Mode 3	Temperature	: 22°C
Test Date	: Dec. 27, 2016	Humidity	: 60%

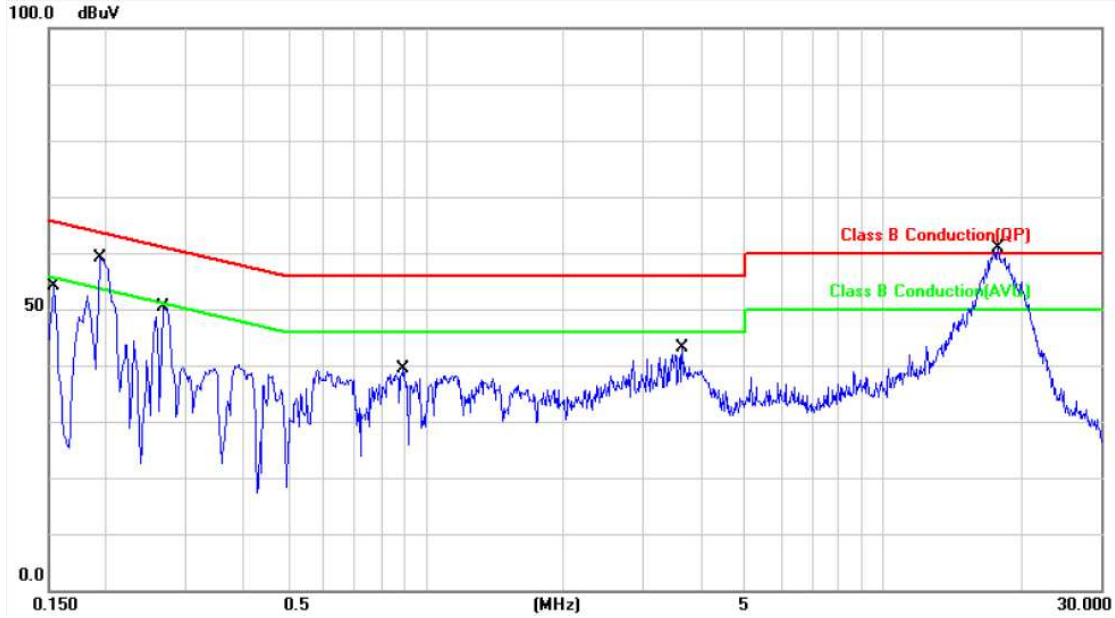

No.	Frequency (MHz)	Factor (dB)	Reading (dBuV)	Level (dBuV)	Limit (dBuV)	Margin (dB)	Detector	P/F
1	0.1539	9.98	37.13	47.11	65.78	-18.67	QP	P
2	0.1539	9.98	15.40	25.38	55.78	-30.40	AVG	P
3	0.1940	9.98	48.11	58.09	63.86	-5.77	QP	P
4	0.1940	9.98	31.86	41.84	53.86	-12.02	AVG	P
5	0.2660	9.96	37.35	47.31	61.24	-13.93	QP	P
6	0.2660	9.96	20.14	30.10	51.24	-21.14	AVG	P
7	0.8980	9.98	27.01	36.99	56.00	-19.01	QP	P
8	0.8980	9.98	14.72	24.70	46.00	-21.30	AVG	P
9	3.6540	10.13	23.64	33.77	56.00	-22.23	QP	P
10	3.6540	10.13	12.60	22.73	46.00	-23.27	AVG	P
11	17.7560	10.54	44.39	54.93	60.00	-5.07	QP	P
12	17.7560	10.54	32.42	42.96	50.00	-7.04	AVG	P

Note: Level = Reading + Factor  
 Margin = Level – Limit  
 Factor = (LISN, ISN, PLC or current probe) Factor + Cable Loss + Attenuator

Test engineer: Peter





#### 4.6. Test Photographs of Power Port

Front View



Rear View





## 5. Test of Radiated Emission

### 5.1. Test Limit

The EUT shall meet the limits of below Table when measured at the measuring distance R in accordance with the methods described in European Standard EN 55032. If the reading on the measuring receiver shows fluctuations close to the limit, the reading shall be observed for at least 15 s at each measurement frequency; the highest reading shall be recorded, with the exception of any brief isolated high reading, which shall be ignored.

**Table 1 – Required highest frequency for radiated measurement**

Highest internal frequency (F <sub>x</sub> )	Highest measured frequency
F <sub>x</sub> ≤ 108 MHz	1 GHz
108 MHz < F <sub>x</sub> ≤ 500 MHz	2 GHz
500 MHz < F <sub>x</sub> ≤ 1 GHz	5 GHz
F <sub>x</sub> > 1 GHz	5 x F <sub>x</sub> up to a maximum of 6 GHz
NOTE 1 For FM and TV broadcast receivers, F <sub>x</sub> is determined from the highest frequency generated or used excluding the local oscillator and tuned frequencies.	
NOTE 2 F <sub>x</sub> is defined in 3.1.19.	

Where the F<sub>x</sub> is unknown, the radiated emission measurements shall be performed up to 6 GHz.

**Table A.2 – Requirements for radiated emissions at frequencies up to 1 GHz for Class A equipment**

Table clause	Frequency range MHz	Measurement		Class A limits dB(μV/m)
		Distance m	Detector type / bandwidth	OATS / SAC (see Table A.1)
A2.1	30 – 230	10	Quasi Peak / 120 kHz	40
	230 – 1 000			47
A2.2	30 – 230	3		50
	230 – 1 000			57
NOTE Apply only A2.1 or A2.2 across the entire frequency range.				

**Table A.3 – Requirements for radiated emissions at frequencies above 1 GHz for Class A equipment**

Table clause	Frequency range MHz	Measurement		Class A limits dB(μV/m)
		Distance m	Detector type / bandwidth	FSOATS (see Table A.1)
A3.1	1 000 – 3 000	3	Average / 1 MHz	56
	3 000 – 6 000			60
A3.2	1 000 – 3 000		Peak / 1 MHz	76
	3 000 – 6 000			80
NOTE Apply A3.1 and A3.2 across the frequency range from 1000 MHz to the highest required frequency of measurement derived from Table 1.				





**Table A.4 – Requirements for radiated emissions at frequencies up to 1 GHz for Class B equipment**

Table clause	Frequency range MHz	Measurement		Class B limits dB( $\mu$ V/m)
		Distance m	Detector type / bandwidth	OATS / SAC (see Table A.1)
A4.1	30 – 230	10	Quasi Peak / 120 kHz	30
	230 – 1 000			37
A4.2	30 – 230	3		40
	230 – 1 000			47

NOTE Apply only table clause A4.1 or A4.2 across the entire frequency range.

**Table A.5 – Requirements for radiated emissions at frequencies above 1 GHz for Class B equipment**

Table clause	Frequency range MHz	Measurement		Class B limits dB( $\mu$ V/m)
		Distance m	Detector type / bandwidth	FSOATS (see Table A.1)
A5.1	1 000 – 3 000	3	Average / 1 MHz	50
	3 000 – 6 000			54
A5.2	1 000 – 3 000		Peak / 1 MHz	70
	3 000 – 6 000			74

NOTE Apply A5.1 and A5.2 across the frequency range from 1000 MHz to the highest required frequency of measurement derived from Table 1.

**Table A.6 – Requirements for radiated emissions from FM receivers**

Table clause	Frequency range MHz	Measurement		Class B limit dB( $\mu$ V/m)		
		Distance m	Detector type / bandwidth	Fundamental	Harmonics	
				OATS/SAC (see Table A.1)	OATS/SAC (see Table A.1)	
A6.1	30 – 230	10	Quasi peak / 120 kHz	50	42	
	230 – 300				42	
	300 – 1 000				46	
A6.2	30 – 230	3		Quasi peak / 120 kHz	60	52
	230 – 300					52
	300 – 1 000					56

NOTE 1 Apply only A.6.1 or A.6.2 across the entire frequency range.  
 NOTE 2 These relaxed limits apply only to emissions at the fundamental and harmonic frequencies of the local oscillator. Signals at all other frequencies shall be compliant with the limits given in Table A.4.

**Table A.12 – Requirements for conducted differential voltage emissions from Class B equipment**

Applicable to						
1.TV broadcast receiver tuner ports (3.1.8) with an accessible connector						
2.RF modulator output ports (3.1.27)						
3.FM broadcast receiver tuner ports (3.1.8) with an accessible connector						
Table clause	Frequency Range MHz	Detector type / bandwidth	Class B limits dB( $\mu$ V) $75\Omega$			Applicability
			Other	Local Oscillator Fundamental	Local Oscillator Harmonics	
A12.1	30 - 950	For frequencies $\leq 1$ GHz	46	46	46	See NOTE 1
	950 – 2 150		46	54	54	
A12.2	950 – 2 150		46	54	54	See NOTE 2
A12.3	30 – 300	Quasi Peak / 120 kHz	46	54	50	See NOTE 3
	300 – 1 000				52	
A12.4	30 - 300	For frequencies $\geq 1$ GHz	46	66	59	See NOTE 4
	300 – 1 000				52	
A12.5	30 - 950				Peak / 1 MHz	46
	950 – 2 150	n/a	54			

NOTE 1 Television receivers (analogue or digital), video recorders and PC TV broadcast receiver tuner cards working in channels between 30 MHz and 1 GHz, and digital audio receivers.

NOTE 2 Tuner units (not the LNB) for satellite signal reception.

NOTE 3 Frequency modulation audio receivers and PC tuner cards.

NOTE 4 Frequency modulation car radios.

NOTE 5 Applicable to EUT2 with RF modulator output ports (for example DVD equipment, video recorders, camcorders and decoders etc.) designed to connect to TV broadcast receiver tuner ports.

NOTE 6 Testing is required at only one EUT supply voltage and frequency.

NOTE 7 The term 'other' refers to all emissions other than the fundamental and the harmonics of the local oscillator.

NOTE 8 The test shall be performed with the device operating at each reception channel.

NOTE 9 The test shall cover the entire frequency range.

## 5.2. Test Procedures

- The EUT was placed on a rotatable table top 0.8 meter above ground.
- The EUT was set 10 meters from the interference receiving antenna which was mounted on the top of a variable height antenna tower.
- The table was rotated 360 degrees to determine the position of the highest radiation.
- The antenna is a half wave dipole and its height is varied between one meter and four meters above ground to find the maximum value of the field strength both horizontal polarization and vertical polarization of the antenna are set to make the measurement.
- For each suspected emission the EUT was arranged to its worst case and then tune the antenna tower (from 1 M to 4 M) and turn table (from 0 degree to 360 degrees) to find the maximum reading.
- Set the test-receiver system to Peak Detect Function and specified bandwidth with Maximum Hold Mode.
- If the emission level of the EUT in peak mode was 6 dB lower than the limit specified, then testing will be stopped and peak values of EUT will be reported, otherwise, the emissions which do not have 6 dB margin will be repeated one by one using the quasi-peak method and reported.

## 5.3. Typical Test Setup

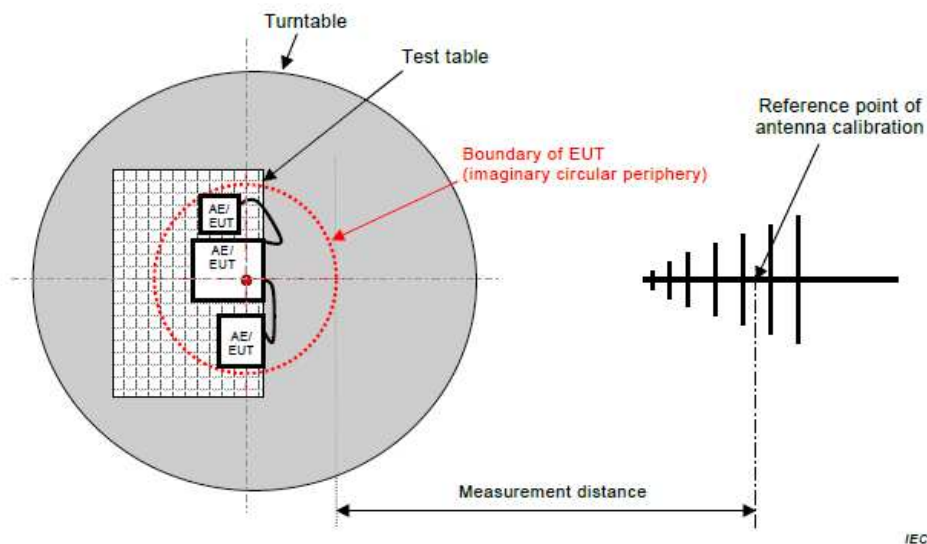
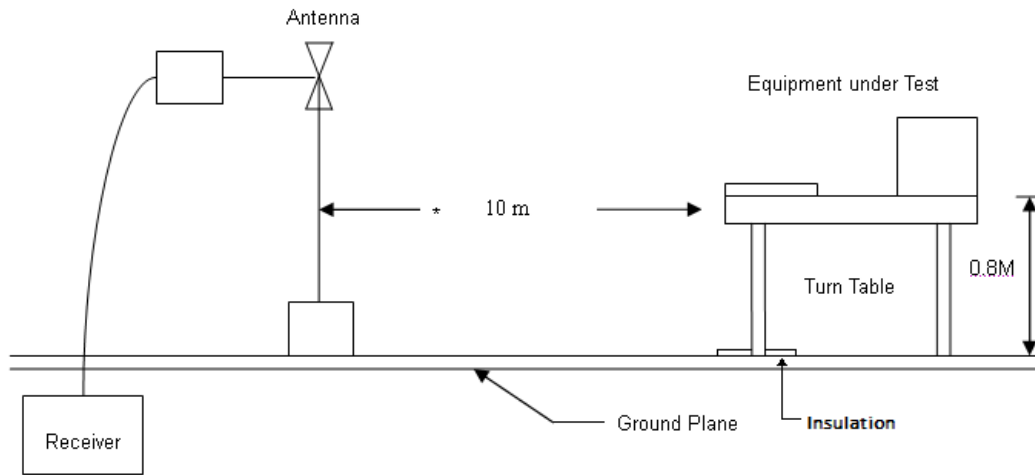
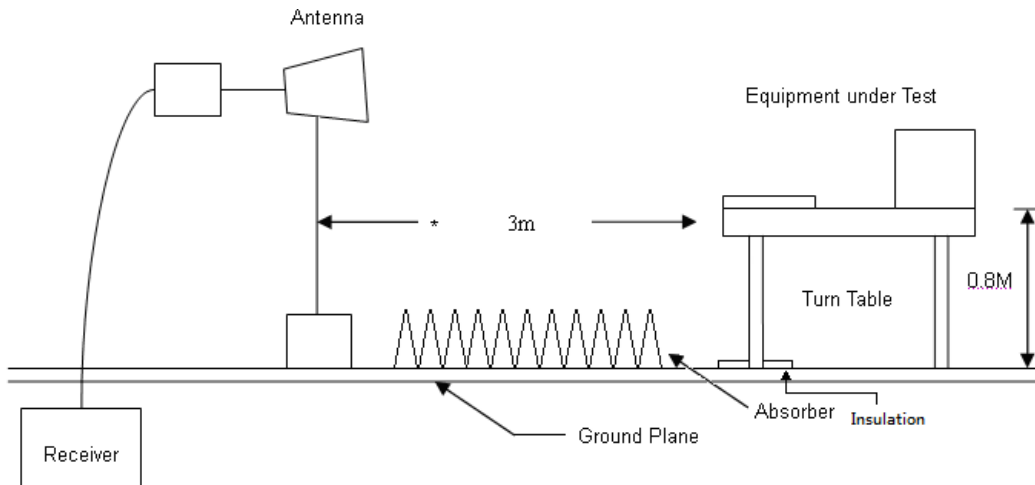

Figure C.1 – Measurement distance

Below 1GHz Test Setup



Above 1GHz Test Setup



5.4. Measurement Equipment

Instrument	Manufacturer	Model No.	Serial No.	Calibration Date	Valid Date
Bilog Antenna	Sunol	JB1	A020514-1	2016/02/17	2017/02/16
Bilog Antenna	Sunol	JB1	A020514-2	2016/03/17	2017/03/16
EMI Receiver	R&S	ESCI3	101402	2016/02/18	2017/02/17
EMI Receiver	R&S	ESCI7	100963	2016/02/25	2017/02/24
Preamplifier	EM Electronics corp.	EM330	60610	2016/02/24	2017/02/23
Preamplifier	EM Electronics corp.	EM330	60611	2016/02/15	2017/02/14
Software	E3	AUDIX	Version: 8.14.806b	N/A	N/A



### 5.5. Test Result and Data (30MHz ~ 1GHz)

Power	: AC 230V	Pol/Phase	: VERTICAL
Test Mode	: Mode 3	Temperature	: 25°C
Test Date	: Dec. 27, 2016	Humidity	: 48%

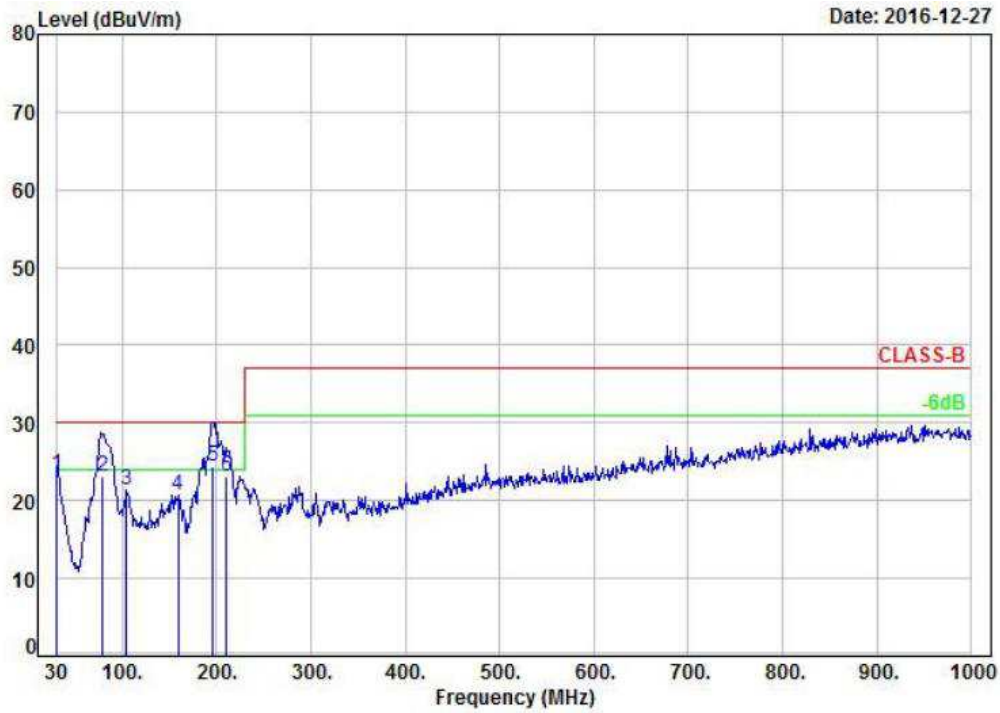

No.	Frequency (MHz)	Factor (dB)	Reading (dBuV)	Level (dBuV)	Limit (dBuV)	Margin (dB)	Detector	Height (cm)	Azimuth (deg)	P/F
1	30.97	-3.69	27.06	23.37	30.00	-6.63	Peak	400	0	P
2	79.00	-16.15	39.23	23.08	30.00	-6.92	QP	100	32	P
3	104.69	-11.91	33.29	21.38	30.00	-8.62	Peak	400	0	P
4	159.01	-10.75	31.54	20.79	30.00	-9.21	Peak	400	0	P
5	195.00	-10.68	35.00	24.32	30.00	-5.68	QP	100	13	P
6	211.00	-12.14	35.21	23.07	30.00	-6.93	QP	100	104	P

Note: Level = Reading + Factor  
 Margin = Level – Limit  
 Factor = Antenna Factor + Cable Loss - Amplifier Factor



Power	: AC 230V	Pol/Phase	: HORIZONTAL
Test Mode	: Mode 3	Temperature	: 25°C
Test Date	: Dec. 27, 2016	Humidity	: 48%

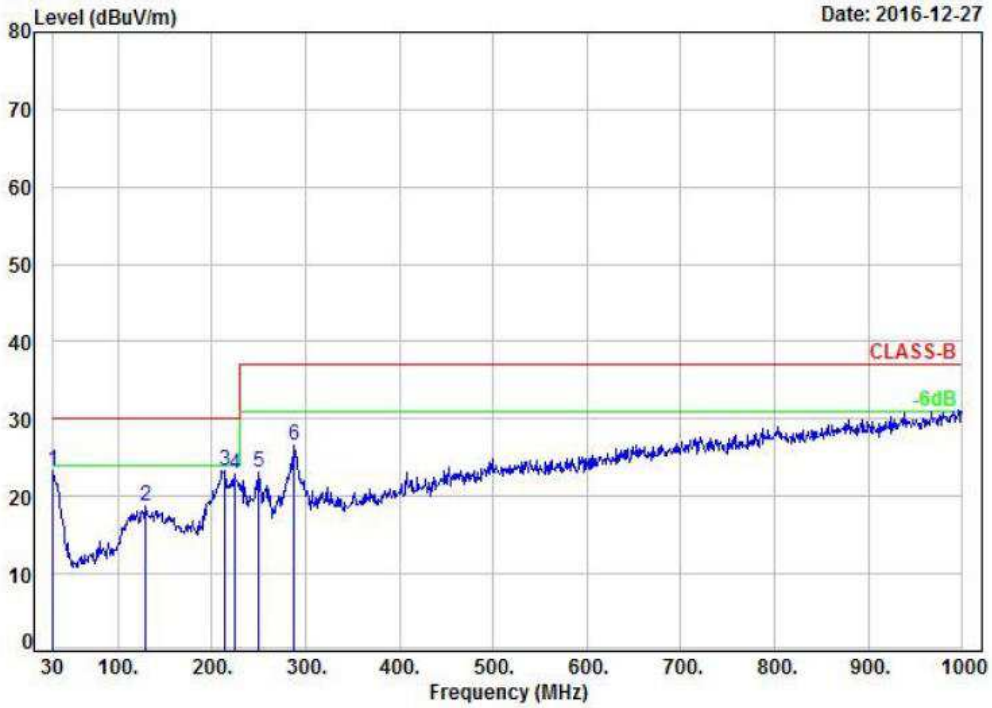

No.	Frequency (MHz)	Factor (dB)	Reading (dBuV)	Level (dBuV)	Limit (dBuV)	Margin (dB)	Detector	Height (cm)	Azimuth (deg)	P/F
1	30.00	-2.52	25.76	23.24	30.00	-6.76	Peak	400	0	P
2	128.94	-9.10	27.75	18.65	30.00	-11.35	Peak	400	0	P
3	213.33	-11.81	35.21	23.40	30.00	-6.60	Peak	400	0	P
4	224.00	-11.37	34.24	22.87	30.00	-7.13	Peak	400	0	P
5	250.19	-10.53	33.68	23.15	37.00	-13.85	Peak	400	0	P
6	288.02	-8.37	34.92	26.55	37.00	-10.45	Peak	400	0	P

Note: Level = Reading + Factor  
 Margin = Level – Limit  
 Factor = Antenna Factor + Cable Loss - Amplifier Factor

Test engineer: Charlie





### 5.6. Test Photographs (30MHz~1GHz)

Front View

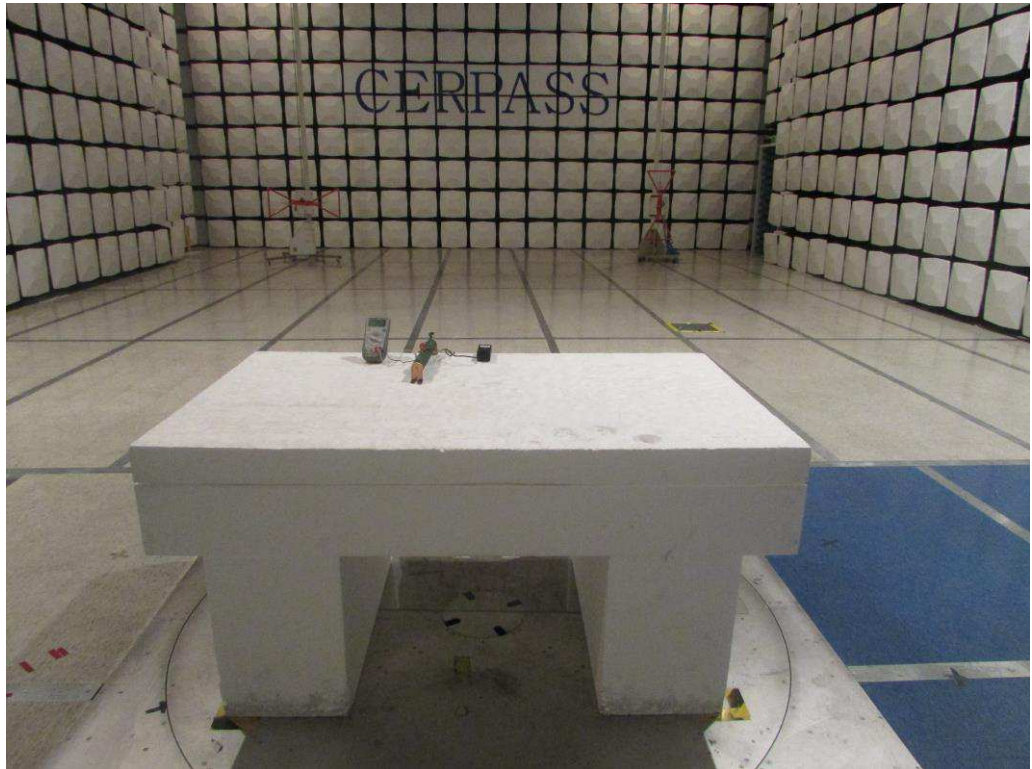

Rear View

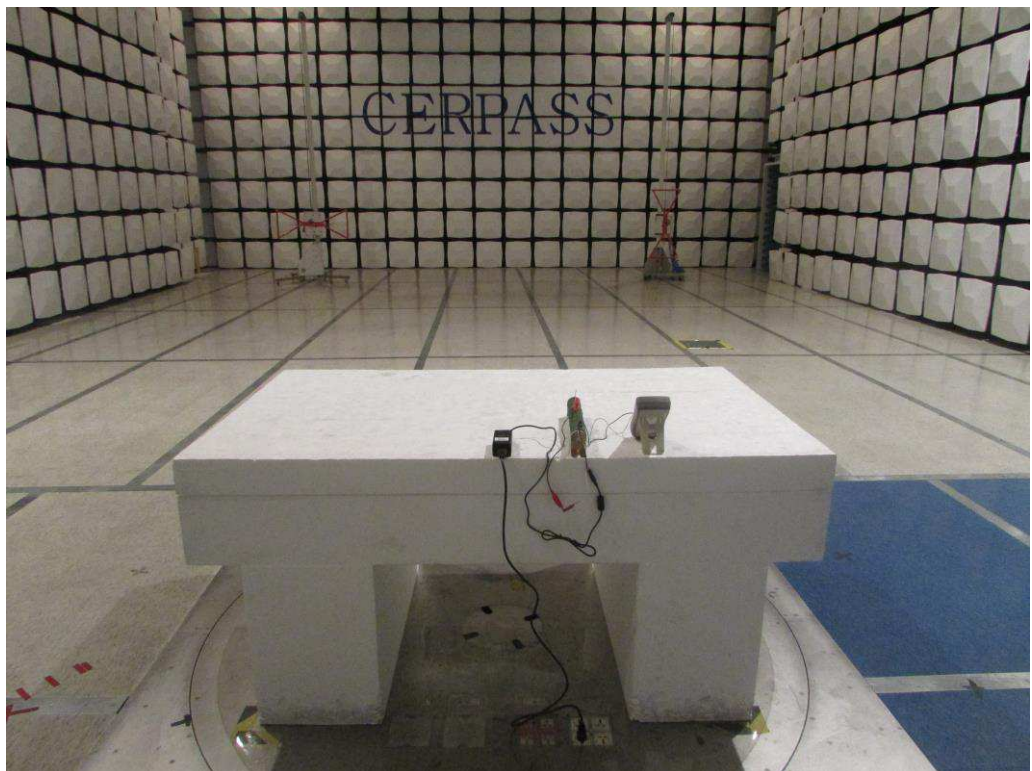



## 6. Harmonics Test

### 6.1. Limits of Harmonics Current Measurement

Limits for Class A equipment		Limits for Class D equipment		
Harmonics Order n	Max. Permissible harmonics current A	Harmonics Order n	Max. Permissible harmonics current per watt mA/W	Max. Permissible harmonics current A
Odd harmonics		Odd Harmonics only		
3	2.30	3	3.4	2.30
5	1.14	5	1.9	1.14
7	0.77	7	1.0	0.77
9	0.40	9	0.5	0.40
11	0.33	11	0.35	0.33
13	0.21	13	0.30	0.21
15<=n<=39	0.15×15/n	15<=n<=39	3.85/n	0.15 x15/n
Even harmonics				
2	1.08			
4	0.43			
6	0.30			
8<=n<=40	0.23×8/n			

NOTE:

1. Class A and Class D are classified according to item section 5 of EN 61000-3-2.
2. According to section 7 of EN 61000-3-2, the above limits for all equipment except for lighting equipment are for all applications having an active input power > 75 W and no limits apply for equipment with an active input power up to and including 75 W.

### 6.2. Test Result and Data

The limits are not specified for equipment with rated power of 75W or less. The EUT meets the above condition, so it conforms to EN 61000-3-2.





## 7. Voltage Fluctuations Test

### 7.1. Test Procedure

The equipment shall be tested under the conditions of **Clause 5**.

The total impedance of the test circuit, excluding the appliance under test, but including the internal impedance of the supply source, shall be equal to the reference impedance.

The stability and tolerance of the reference impedance shall be adequate to ensure that the overall accuracy of  $\pm 8\%$  is achieved during the whole assessment procedure.

### 7.2. Measurement Equipment

Instrument	Manufacturer	Model No.	Serial No.	Calibration Date	Valid Date
Power & Harmonics Analyzer	Teseq	Teseq Profline 2105	1422A00918	2015/03/20	2016/03/19



### 7.3. Test Result and Data

Final Test Result	: <b>PASS</b>	Temperature	: 22 °C
Basic Standard	: EN 61000-3-3	Relative Humidity	: 53 %
		Test Data	: Oct. 16, 2015

Test Result: Pass                      Status: Test Completed

Pst<sub>i</sub> and limit line    European Limits

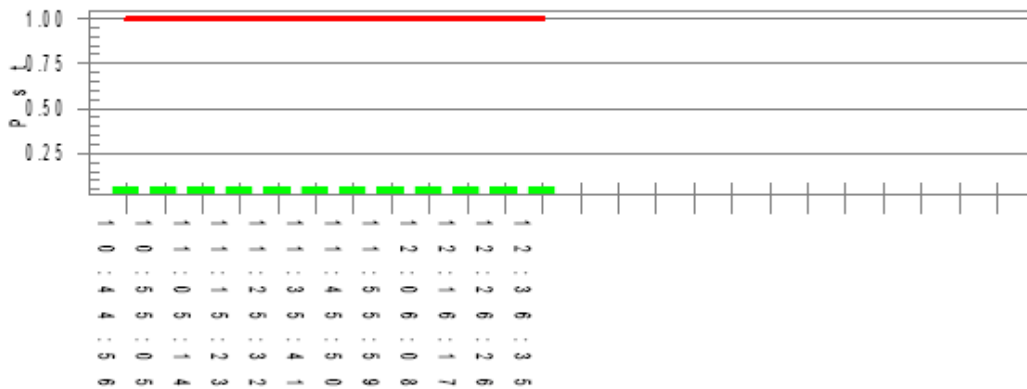

Plt and limit line

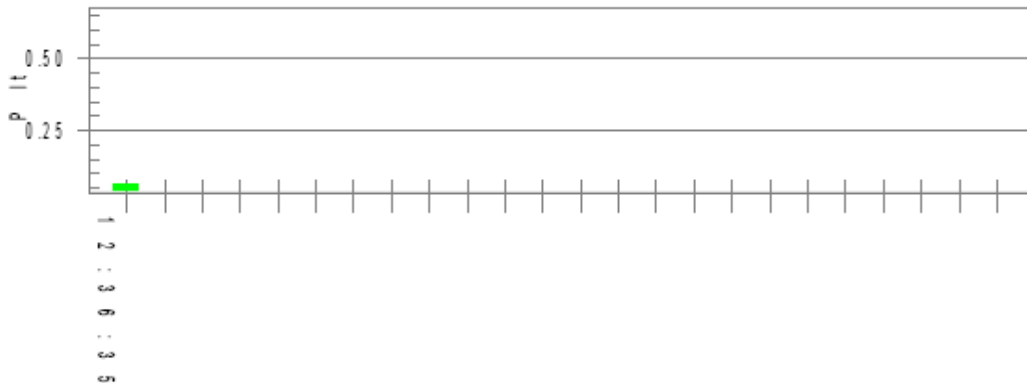

Parameter values recorded during the test:

Vrms at the end of test (Volt):	229.92	Test limit (%):	N/A	N/A
Highest dt (%):	0.00	Test limit (mS):	500.0	Pass
T-max (mS):	0	Test limit (%):	3.30	Pass
Highest dc (%):	0.00	Test limit (%):	4.00	Pass
Highest dmax (%):	0.03	Test limit:	1.000	Pass
Highest Pst (10 min. period):	0.064	Test limit:	0.650	Pass
Highest Plt (2 hr. period):	0.064			

Test engineer:           Dora



#### 7.4. Test Photographs





## 8. Electrostatic Discharge Immunity Test

### 8.1. Test Procedure

- a. In the case of air discharge testing the climatic conditions shall be within the following ranges:
  - ambient temperature: 15°C to 35°C;
  - relative humidity : 30% to 60%;
  - atmospheric pressure : 86 KPa (860 mbar) to 106 KPa (1060 mbar).
- b. Test programs and software shall be chosen so as to exercise all normal modes of operation of the EUT. The use of special exercising software is encouraged, but permitted only where it can be shown that the EUT is being comprehensively exercised.
- c. The test voltage shall be increased from the minimum to the selected test severity level, in order to determine any threshold of failure. The final severity level should not exceed the product specification value in order to avoid damage to the equipment.
- d. The test shall be performed with both air discharge and contact discharge. On reselected points at least 10 single discharges (in the most sensitive polarity) shall be applied on air discharge. On reselected points at least 25 single discharges (in the most sensitive polarity) shall be applied on contact discharge.
- e. For the time interval between successive single discharges an initial value of one second is recommended. Longer intervals may be necessary to determine whether a system failure has occurred.
- f. In the case of contact discharges, the tip of the discharge electrode shall touch the EUT before the discharge switch is operated.
- g. In the case of painted surface covering a conducting substrate, the following procedure shall be adopted :
  - If the coating is not declared to be an insulating coating by the equipment manufacturer, then the pointed tip of the generator shall penetrate the coating so as to make contact with the conducting substrate.
  - Coating declared as insulating by the manufacturer shall only be submitted to the air discharge.
  - The contact discharge test shall not be applied to such surfaces.
- h. In the case of air discharges, the round discharge tip of the discharge electrode shall be approached as fast as possible (without causing mechanical damage) to touch the EUT . After each discharge, the ESD generator (discharge electrode) shall be removed from the EUT. The generator is then retriggered for a new single discharge. This procedure shall be repeated until the discharges are completed. In the case of an air discharge test, the discharge switch, which is used for contact discharge, shall be closed.

## 8.2. Test Setup for Tests Performed in Laboratory

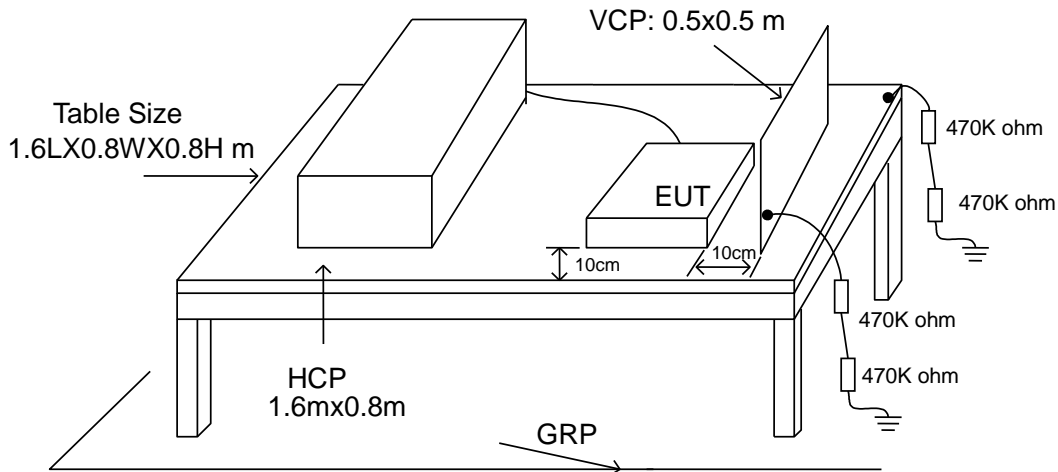

The test setup consists of the test generator, EUT and auxiliary instrumentation necessary to perform DIRECT and INDIRECT application of discharges to the EUT as applicable, in the follow manner :

- a. Contact Discharge to the conductive surfaces and to coupling plane;
- b. Air Discharge at insulating surfaces.

The preferred test method is that of type tests performed in laboratories and the only accepted method of demonstrating conformance with this standard. The EUT was arranged as closely as possible to arrangement in final installed conditions.

A ground reference plane was provided on the floor of the test site. It was a metallic sheet (copper or aluminum) of 0.25 mm, minimum thickness; other metallic may be used but they shall have at least 0.65 mm thickness. In the CerpPASS Technology Corp., we provided 1 mm thickness stainless steel ground reference plane. The minimum size of the ground reference plane is 2.5 m x 2.5 m, the exact size depending on the dimensions of the EUT. It was connected to the protective grounding system.

The EUT was arranged and connected according to its functional requirements. A distance of 1m minimum was provided between the EUT and the wall of the lab. and any other metallic structure. In cases where this length exceeds the length necessary to apply the discharges to the selected points, the excess length shall, where possible, be placed non-inductively off the ground reference plane and shall not come closer than 0.2m to other conductive parts in the test setup.

Where the EUT is installed on a metal table, the table was connected to the reference plane via a cable with a 470k ohm resistor located at each end, to prevent a build-up of charge. The test setup was consist a wooden table, 0.8m high, standing on the ground reference plane. A HCP, 1.6 m x 0.8 m, was placed on the table. The EUT and cables was isolated from the HCP by an insulating support 0.5 mm thick. The VCP size, 0.5 m x 0.5 m.



### 8.3. Test Severity Levels

Contact Discharge		Air Discharge	
Level	Test Voltage (KV) of Contact discharge	Level	Test Voltage (KV) of Air Discharge
1	±2	1	±2
2	±4	2	±4
3	±6	3	±8
4	±8	4	±15
X	Specified	X	Specified

Remark: "X" is an open level.

### 8.4. Measurement Equipment

Instrument	Manufacturer	Model No.	Serial No.	Calibration Date	Valid Date
ESD Simulator	SCHAFFNER	NSG438	878	2015/05/06	2016/05/05



8.5. Test Result and Data

Final Test Result : **PASS**  
 Pass performance criteria : A  
 Required performance criteria : B  
 Basic Standard : IEC 61000-4-2  
 Product Standard : EN 55024  
 Test Voltage : ±2 / ±4 / ±8 KV for air discharge,  
 ±2 / ±4 KV for contact discharge  
 Temperature : 23 °C  
 Relative Humidity : 50 %  
 Atmospheric Pressure : 1005 hPa  
 Test Date : Oct. 16, 2015

	Contact Discharge				Air Discharge					
	25 times / each				10 times / each					
Voltage	2 KV		4 KV		2 KV		4 KV		8 KV	
Point\Polarity	+	-	+	-	+	-	+	-	+	-
HCP	A	A	A	A	---	---	---	---	---	---
VCP	A	A	A	A	---	---	---	---	---	---
Case	---	---	---	---	A	A	A	A	A	A
Power Port	---	---	---	---	A	A	A	A	A	A
LED	---	---	---	---	A	A	A	A	A	A

Note: "A" means the EUT function is normal working during the test.

Test engineer: Dora



### 8.6. Test Photographs







## 9. Radio Frequency Electromagnetic Field Immunity Test

### 9.1. Test Procedure

- The equipment to be tested is placed in the center of the enclosure on a wooden table. The equipment is then connected to power and signal leads according to pertinent installation instructions.
- The antenna which is enabling the complete frequency range of 80-1000 MHz is placed 3m away from the equipment. The required field strength is determined by placing the field strength meter(s) on top of or directly alongside the equipment under test and monitoring the field strength meter via a remote field strength indicator outside the enclosure while adjusting the continuous-wave to the applicable antennae.
- The test is normally performed with the antenna facing the most sensitive side of the EUT. The polarization of the field generated by the bucolical antenna necessitates testing each position twice, once with the antenna positioned vertically and again with the antenna positioned horizontally. The circular polarization of the field from the log-spiral antenna makes a change of position of the antenna unnecessary.
- At each of the above conditions, the frequency range is swept 80-1000 MHz, pausing to adjust the R.F. signal level or to switch oscillators and antenna. The rate of sweep is in the order of  $1.5 \times 10^{-3}$  decades/s. The sensitive frequencies or frequencies of dominant interest may be discretely analyzed.

### 9.2. Test Severity Levels

Frequency Band : 80-1000 MHz	
Level	Test field strength (V/m)
1	1
2	3
3	10
X	Specified
Remark: "X" is an open class.	

### 9.3. Measurement Equipment

Instrument	Manufacturer	Model No.	Serial No.	Calibration Date	Valid Date
Amplifiers 80-1000MHz/100W	SCHAFFNER	CBA9413B	43510	N/A	N/A
Amplifiers 80-3000MHz/20W	SCHAFFNER	CBA9428	43515	N/A	N/A
Antenna	SCHAFFNER	CBL6141A	4257	N/A	N/A
Power Meter	Boonton	4231A-01	115902	2015/09/07	2016/09/06
Field Probe	HOLADAY	HI-6105	144727	2015/08/28	2016/08/27
Power Sensor	Boonton	51011-EMC	33312	2015/09/07	2016/09/06
Signal Generator	KEYSIGHT	N5171B	MY503051326	2015/09/04	2016/09/03



9.4. Test Result and Data

Final Test Result : **PASS**  
 Pass performance criteria : A  
 Required performance criteria : A  
 Basic Standard : IEC 61000-4-3  
 Product Standard : EN 55024  
 Frequency Range : 80~1000 MHz  
 Temperature : 22°C  
 Relative Humidity : 56 %  
 Atmospheric Pressure : 1009 hPa  
 Test Date : Oct. 16, 2015

Modulation : AM 80% , 1KHz sine wave, Dwell time: 3 S Frequency Step Size : 1 % of preceding frequency value				
Frequency (MHz)	Antenna Polarization	Face	Field strength (V/m)	Result
80~1000	Vertical	Front	3 V/m	A
80~1000	Vertical	Rear	3 V/m	A
80~1000	Vertical	Left	3 V/m	A
80~1000	Vertical	Right	3 V/m	A
80~1000	Horizontal	Front	3 V/m	A
80~1000	Horizontal	Rear	3 V/m	A
80~1000	Horizontal	Left	3 V/m	A
80~1000	Horizontal	Right	3 V/m	A

Note: "A" means the EUT function is normal working during the test.

Test engineer:       Dora



### 9.5. Test Photographs

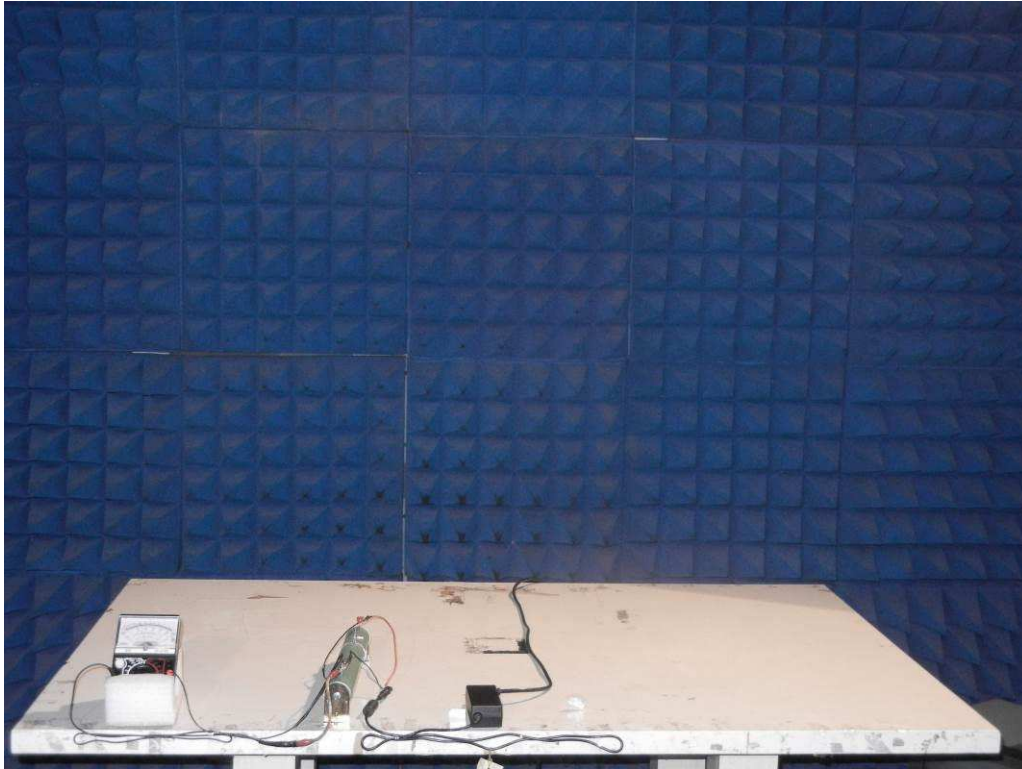



## 10. Electrical Fast Transient/ Burst Immunity Test

### 10.1. Test Procedure

- a. In order to minimize the effect of environmental parameters on test results, the climatic conditions when test is carrying out shall comply with the following requirements:
  - ambient temperature: 15°C to 35°C;
  - relative humidity : 45% to 75%;
  - Atmospheric pressure: 86 Kpa (860 mbar) to 106 Kpa (1060 mbar).
- b. In order to minimize the effect of environmental parameters on test results, the electromagnetic environment of the laboratory shall not influence the test results.
- c. The variety and diversity of equipment and systems to be tested make it difficult to establish general criteria for the evaluation of the effects of fast transients/bursts on equipment and systems.
- d. Test on Power Line:
  - The EFT/B-generator was located on the GRP.  
For floor standing equipment 1,0 m  
For table top equipment 0,5 m
  - The EFT/B-generator provides the ability to apply the test voltage in a non-symmetrical condition to the power supply input terminals of the EUT.
- e. Test on Communication Lines
  - The coupling clamp is composed of a clamp unit for housing the cable (length more than 3 m), and was placed on the GRP.
  - The coupling clamp provides the ability of coupling the fast transient/bursts to the cable under test.
- f. The test results may be classified on the basic of the operating conditions and the functional specification of the equipment under test, according to the following performance criteria :
  - Normal performance within the specification limits.
  - Temporary degradation or loss of function or performance which is self-recoverable.
  - Temporary degradation or loss of function or performance which requires operator intervention or system reset.
  - Degradation or loss of function which is not recoverable due to damage of equipment (components).

### 10.2. Test Severity Levels

The following test severity levels are recommended for the fast transient/burst test :

Open circuit output test voltage $\pm 10\%$		
Level	On Power Supply	On I/O signal, data and control line
1	0.5 KV	0.25 KV
2	1.0 KV	0.50 KV
3	2.0 KV	1.00 KV
4	4.0 KV	2.00 KV
X	Specified	Specified

Remark : “ X ” is an open level. The level is subject to negotiation between the user and manufacturer or is specified by the manufacturer.

### 10.3. Measurement Equipment

Instrument	Manufacturer	Model No.	Serial No.	Calibration Date	Valid Date
TESQ NSG3060	TESQ	NSG3060	1385	2015/03/17	2016/03/16



10.4. Test Result and Data

Final Test Result : **PASS**  
 Pass performance criteria : A  
 Required performance criteria : B  
 Basic Standard : IEC 61000-4-4  
 Product Standard : EN 55024  
 Test Voltage : On Power Supply --  $\pm 0.5$  KV,  $\pm 1.0$  KV  
 Temperature : 22°C  
 Relative Humidity : 56 %  
 Atmospheric Pressure : 1009 hPa  
 Test Date : Oct. 16, 2015

Pulse : 5/50 ns		Repetition Rate: <u>5 kHz</u>			
Burst : 15m/300ms		Test time : 1 min/each condition			
Voltage/ Mode/ Polarity/ Result/ Phase		<u>0.5 kV</u>		<u>1.0 kV</u>	
		+	-	+	-
Power Line	L	A	A	A	A
	N	A	A	A	A
	L-N	A	A	A	A
	PE	A	A	A	A
	L-PE	A	A	A	A
	N-PE	A	A	A	A
	L-N-PE	A	A	A	A

Note: "A" Means the EUT function is normal working during the test.

Test engineer: Dora



### 10.5. Test Photographs





## 11. Surge Immunity Test

### 11.1. Test Procedure

- a. Climatic conditions  
The climatic conditions shall comply with the following requirements :
  - ambient temperature : 15 °C to 35 °C
  - relative humidity : 10 % to 75 %
  - atmospheric pressure : 86 kPa to 106 kPa ( 860 mbar to 1060 mbar )
- b. Electromagnetic conditions  
the electromagnetic environment of the laboratory shall not influence the test results.
- c. The test shall be performed according the test plan that shall specify the test set-up with
  - generator and other equipment utilized;
  - test level ( voltage/current );
  - generator source impedance;
  - internal or external generator trigger;
  - number of tests : at least five positive and five negative at the selected points;
  - repetition rate : maximum 1/min.
  - inputs and outputs to be tested;
  - representative operating conditions of the EUT;
  - sequence of application of the surge to the circuit;
  - phase angle in the case of AC. power supply;
  - actual installation conditions, for example :
    - AC : neutral earthed,
    - DC : ( + ) or ( - ) earthed to simulated the actual earthing conditions.
- d. If not otherwise specified the surges have to be applied synchronized to the voltage phase at the zero-crossing and the peak value of the AC. voltage wave ( positive and negative ).
- e. The surges have to be applied line to line and line(s) and earth. When testing line to earth, the test voltage has to be applied successively between each of the lines and earth, if there is no other specification.
- f. The test procedure shall also consider the non-linear current-voltage characteristics of the equipment under test. Therefore the test voltage has to be increased by steps up to the test level specified in the product standard or test plan.
- g. All lower levels including the selected test level shall be satisfied. For testing the secondary protection, the output voltage of the generator shall be increased up to the worst-case voltage breakdown level ( let-through level ) of the primary protection.
- h. If the actual operating signal sources are not available, that may be simulated. Under no circumstances may the test level exceed the product specification. The test shall be carried out according to a test plan.
- i. To find all critical points of the duty cycle of the equipment, a sufficient number of positive and negative test pulses shall be applied. For acceptance test previously unstressed equipment shall be used to the protection devices shall be replaced.

### 11.2. Test Severity Level

Level	Open-circuit test voltage (kV)	
	Line-to-line	Line-to-ground <sup>b</sup>
1	---	0.5
2	0.5	1.0
3	1.0	2.0
4	2.0	4.0
X <sup>a</sup>	Special	Special

<sup>a</sup> "X" and be any level, above, below or in between the others. The level shall be specified in the dedicated equipment specification.

<sup>b</sup> For symmetrical interconnection lines the test can be applied to multiple lines simultaneously with respect to ground, i.e. "lines to ground".



### 11.3. Measurement Equipment

Instrument	Manufacturer	Model No.	Serial No.	Calibration Date	Valid Date
EMC Test System	Teseq	NSG3060	1385	2016/03/15	2017/03/14

### 11.4. Test Result and Data

Final Test Result : **PASS**  
 Pass performance criteria : A  
 Required performance criteria : B  
 Basic Standard : IEC 61000-4-5  
 Product Standard : EN 55024  
 Test Voltage : Input AC Power Port -- ± 0.5 kV, ± 1.0 kV, ± 2.0 kV  
 Temperature : 25°C  
 Relative Humidity : 50 %  
 Atmospheric Pressure : 1015 hPa  
 Test Date : Dec. 29, 2016

#### Power Port

Waveform : 1.2/50µs(8/20µs)		Repetition rate : 60 sec		Time : 5 time/each condition		
Phase Voltage / Mode / Polarity / Result		0°	90°	180°	270°	
0.5 kV, 1.0kV	L-N	+	A	A	A	A
		-	A	A	A	A
0.5 kV, 1.0kV, 2.0kV	L-PE	+	A	A	A	A
		-	A	A	A	A
	N-PE	+	A	A	A	A
		-	A	A	A	A

Note: "A" means the EUT function is normal working during the test.

Test engineer: Eric





### 11.5. Test Photographs





## 12. Conduction Disturbances induced by Radio-Frequency Fields

### 12.1. Test Procedure

- a. The EUT shall be operated within its intended climatic conditions. The temperature and relative humidity should be recorded.
- b. This test method test can be performed without using a sell shielded enclosure. This is because the disturbance levels applied and the geometry of the setups are not likely to radiated a high amount of energy, especially at the lower frequencies. If under certain circumstances the radiated energy is too high, a shielded enclosure has to be used.
- c. The test shall be performed with the test generator connected to each of the coupling and decoupling devices in turn while the other non-excited RF-input ports of the coupling devices are terminated by a 50 ohm load resistor.
- d. The frequency range is swept from 150 KHz to 80 MHz, using the signal levels established during the setting process, and with the disturbance signal 80% amplitude modulated with a 1KHz sign wave, pausing to adjust the RF-signal level or to switch coupling devices as necessary. The rate of sweep shall no exceed  $1.5 \times 10^{-3}$  decades/s. Where the frequency is swept incrementally, the step size shall no exceed 1% of the start and thereafter 1% of the preceding frequency value.
- e. The dwell time at each frequency shall not be less than the time necessary for the EUT to be exercised, and able to respond. Sensitive frequencies e.g. clock frequency (ies) and harmonics or frequencies of dominant interest shall be analyzed separately.
- f. An alternative test procedure may be adopted, wherein the frequency range is swept incrementally, with a step size not exceeding 4% of the start ad thereafter 4% of the preceding frequency value. The test level should be at least twice the value of the specified test level.
- g. In cases of dispute, the test procedure using a step size not exceeding 1% of the start and thereafter 1% of preceding frequency value shall take precedence.
- h. Attempts should be made to fully exercise the EUT during testing, and to fully interrogate all exercise modes selected for susceptibility.
- i. The use of special exercising programs is recommended.
- j. Testing shall be performed according to a Test Plan, which shall be included in the test report.
- k. It may be necessary to carry out some investigatory testing in order to establish some aspects of the test plan.

### 12.2. Test Severity Levels

Level	Voltage Level ( e.m.f. )
1	1 V
2	3 V
3	10 V
x	Specified
NOTE - x is an open class. This level can be specified in the product specification.	

### 12.3. Measurement Equipment

Instrument	Manufacturer	Model No.	Serial No.	Calibration Date	Valid Date
CS GENERATOR	Schaffner	NSG 2070	1059	2015/09/08	2016/09/07
CDN (M2+M3)	Schaffner	CDN M016	25111	2015/09/08	2016/09/07





### 12.5. Test Photographs

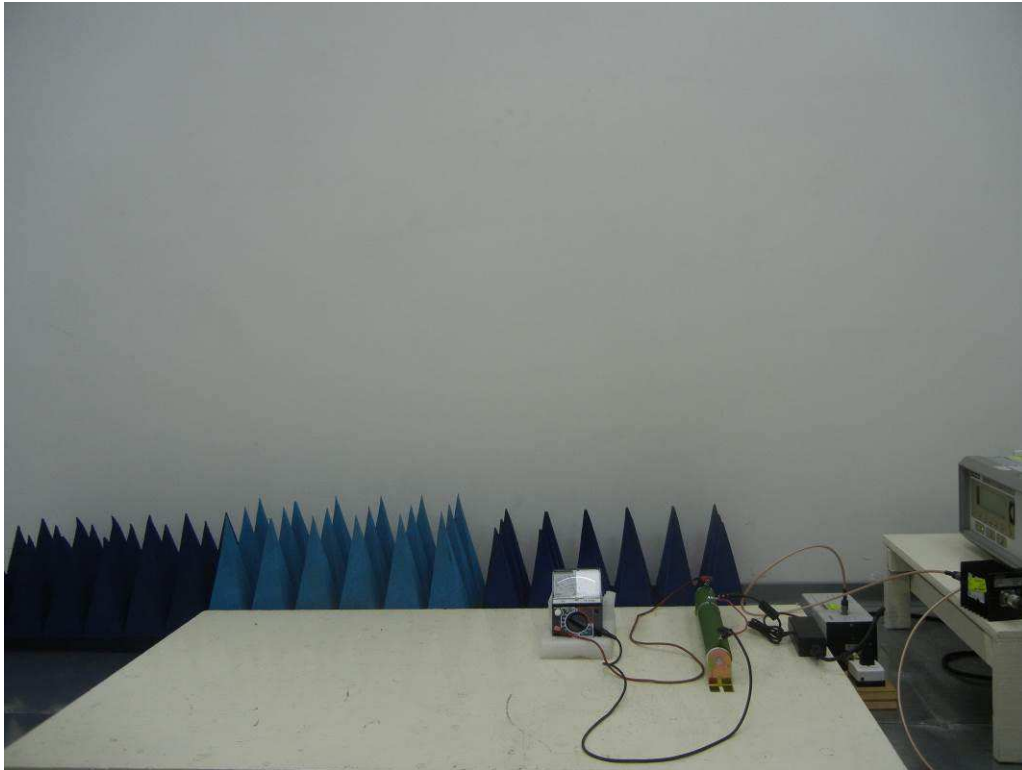

### 13. Power Frequency Magnetic Field Immunity Test

#### 13.1. Test Setup

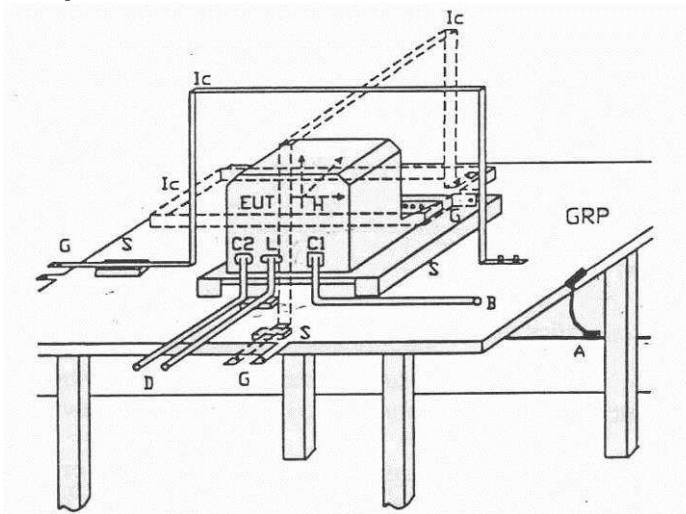

- GPR : Ground plane
- A : Safety earth
- S : Insulating support
- EUT : Equipment under test
- Lc : Induction coil
- E : Earth terminal
- C1 : Power supply circuit
- C2 : Signal circuit
- L : Communication line
- B : To power supply source
- D : To signal source, simulator
- G : To the test generator

#### 13.2. Test Severity Levels

Level	Magnetic field strength (A/m)
1	1
2	3
3	10
4	30
5	100
X <sup>1)</sup>	special

NOTE 1 "X" is an open level. This level can be given in the product specification.

#### 13.3. Measurement Equipment

Instrument	Manufacturer	Model No.	Serial No.	Calibration Date	Valid Date
Magnetic Field Generator	KeyTek	F-1000-4-8-G-125A	N/A	2015/09/09	2016/09/08



### 13.4. Test Result and Data

Final Test Result : **PASS**  
Pass performance criteria : A  
Required performance criteria : A  
Basic Standard : IEC 61000-4-8  
Product Standard : EN 55024  
Temperature : 24 °C  
Relative Humidity : 54 %  
Atmospheric Pressure : 1009 hPa  
Test Date : Oct. 16, 2015

Power Frequency Magnetic Field : <u>50</u> Hz, <u>1</u> A/m		
Coil Orientation	Testing duration	Results
X-axis	1.0 Min	A
Y-axis	1.0 Min	A
Z-axis	1.0 Min	A

Note: "A" Mean the EUT function is normal working during the test.

Test engineer: Yosa



### 13.5. Test Photographs





## 14. Voltage Dips and Voltage Interruptions Immunity Test Setup

### 14.1. Test Conditions

1. Source voltage and frequency: 100/230/240 / 50Hz, Single phase.
2. Test of interval: 10 sec.
3. Level and duration: Sequence of 3 dips/interrupts.
4. Voltage rise (and fall) time: 1 ~ 5  $\mu$ s.
5. Test severity:

Test mode	Test level UT %	Durations (period)
Voltage interruptions	>95%	250
Voltage dips	30%	25
	>95%	0.5

### 14.2. Measurement Equipment

Instrument	Manufacturer	Model No.	Serial No.	Calibration Date	Valid Date
TESQ NSG3060	TESQ	NSG3060	1385	2015/03/17	2016/03/16





14.3. Test Result and Data

Final Test Result : **PASS**  
 Pass performance Criteria : B for voltage interruption, A for voltage dips  
 Required performance Criteria : C for voltage interruption, B/C for voltage dips  
 Basic Standard : IEC 61000-4-11  
 Product Standard : EN 55024  
 Temperature : 24°C  
 Relative Humidity : 54 %  
 Atmospheric Pressure : 1009 hPa  
 Test Date : Oct. 16, 2015

Voltage(UT): AC <u>100/230/240</u> V <u>50</u> Hz Interval(s) : <u>10s</u> Times : <u>3</u>				
Test mode	Test level UT %	Durations (period)	Phase / Result	
			0°	180°
Voltage interruptions	>95%	250	B	B
Voltage dips	30%	25	A	A
	>95%	0.5	A	A

Note: "A" means the EUT function is normal working during the test.  
 " B" means the EUT function is affected during the test, but it can be recovered automatically, after a while.

Test engineer:       Dora



#### 14.4. Test Photographs

